

SIGNAL CORPS LABORATORIES
FORT MONMOUTH, NEW JERSEY

GAG:F

February 14, 1933

DESCRIPTION AND OPERATING INSTRUCTIONS

FOR

CONVERTER, TYPE M-134

I. REFERENCES:

- a. Photographs (Figs. 1 to 8 inclusive), attached.
- b. Wiring Diagram (ES-B-1177-A), attached.
- c. Disc Wiring (ES-A-1178-A), attached.
- d. Disc Pin Arrangement (ES-A-1179-A), attached.
- e. Tape Transmitter Wiring (ES-A-1180-A), attached.
- f. Schematic Diagram (ES-A-1181-A), attached.

II. DESCRIPTION:

The converter, type M-134, is a highly portable unit complete within itself for the performance of the various functions required. The weight of the complete unit (without batteries) is approximately 22 lbs. and the dimensions are approximately 12" long, 11" wide, and 9" high. The unit consists of an assembly of certain interrelated devices which are described individually hereinafter. An aluminum cover is furnished to protect the operating elements from dust and injury. Binding posts are provided for connection to an 8-volt battery.

III. DETAILED DESCRIPTION:a. Keyboard.

Reference Figs. 1, 5, 8, and drawing ES-A-1181-A. The keyboard is a conventional typewriter keyboard arrangement with the exception that all characters, other than the twenty-six letters of the alphabet, have been removed. The keybars are equipped with contact jaws positioned above pertinent contact reeds. These details are shown in 1, Fig. 8. Depression of a given key serves to close the pertaining contact jaws and reed in a circuit from one battery binding post, to the drum or disc, thru the disc to a lamp, thru the lamp return to battery. The relationship of the disc will be described more fully hereinafter. Upon releasing the key a trigger latch is operated by the upward motion of the keybar. This trigger latch serves to close momentarily two sets of contacts and upon a further elevation

2-14-33

Description and Operating Instructions for Converter, type M-134.

Sheet #2

of the keybar to open these two sets of contacts. To summarize, the two sets of contacts are closed momentarily during the return of a given key to the normal position after having been depressed. These contacts, known as the tape stepping contacts are shown as detail 1, Fig. 5. They serve two purposes, i.e., to step forward the tape by energizing the tape stepping magnet, and at the same time to short circuit the disc transmitter and tape transmitter contacts. From a circuit standpoint all keybars are in common electrically, are connected to negative battery, and are insulated from the frame of the unit. This feature should be borne in mind whenever, for any reason, the various circuits are being tested to clear trouble.

It will be necessary that the key contacts and the tape stepping contacts be inspected as occasion warrants. The key contacts are of the self-wiping type and should require but little attention. The tape stepping contacts, however, may require an occasional cleaning due to the fact that upon operation these contacts make and break a current of about four amperes in a circuit containing appreciable inductance. A 2-mu f condenser is connected across the contacts and serves to dissipate the inductive spark but the minor resultant spark may in time pit or mar the contacts and hence these contacts should be cleaned and burnished occasionally. A dental file and burnishing tool may be used for the purpose.

b. Keyboard Lock Mechanism.

Reference Fig. 8 and drawing ES-A-1181-A. The keyboard lock mechanism functions to prevent the depression of any key on the keyboard during the time the motor is energized. As will be noted on drawing SC-A-1181-A, the keyboard locking magnet is in parallel with the motor and hence the magnet and motor are energized or deenergized simultaneously. The magnet is shown as detail 2, Fig. 8, and details 3 and 4 are the lock-out bar and the universal bar, respectively. The magnet armature is connected by a drag link to the lock-out bar. With the magnet armature in the normal or deenergized position, the universal bar is free and hence any key may be depressed. Upon the magnet armature being energized and moving forward, the lock-out bar is likewise moved by means of the drag link into a position where a member of the lock-out bar interferes with the depression of the universal bar and hence with the depression of any key on the keyboard. The keyboard locking mechanism should not require any particular attention other than an occasional oiling of the lock-out bar within the guides.

c. Motor.

Reference Fig. 6, drawing ES-B-1177-A, and drawing ES-A-1181-A. A small d-c motor, acting thru a proper transmission, is used as the prime mover for rotating the disc. This motor is manufactured by the Bodine Co. and rated as 6-volt, d-c shunt wound, 1/200 hp, type V, 2000 rpm. Actually the motor is energized from an 8-volt source and the rpm is somewhat below

2-14-33

Description and Operating Instructions for Converter, type M-134. Sheet #3

2000, dependent upon the load. The motor is started and stopped automatically under the action of the control relay, the relay functioning to make and break the circuit between the battery and the motor. Under load the motor takes approximately 5 amperes. Because of this relatively high current value, the start-stop contacts on the relay are shunted by a 2- μ f condenser with a view to reducing the arcing to a minimum, thus protecting the contacts. Failure of the motor to function will usually be traced to dirty relay contacts or maladjustment of these contacts rather than to any particular trouble within the motor proper. However, dependent upon usage it may be necessary upon occasion to clean the motor commutator, inasmuch as in a low voltage system of this type contact resistance is of importance and should be kept as low as practicable. These same comments as regards contact resistance are applicable throughout the elements of the converter.

d. Transmission.

Reference Fig. 3, drawing ES-B-1177-A, and drawing ES-A-1181-A. The transmission comprises the means for transmitting the rotary motion of the motor shaft to the disc intermittently. The motor shaft is connected to an auxiliary drive shaft thru two bevel gears the ratio of which is 1 to 1. The auxiliary drive shaft is equipped with a positive clutch which functions to engage or disengage the auxiliary drive shaft from a hollow sleeved worm carried on the shaft. The clutch is described in detail hereinafter. The worm is meshed into a worm wheel the ratio being 44 to 1, that is 44 revolutions of the worm performs 1 revolution of the worm wheel. The worm wheel is attached to a shaft which serves to drive the disc. The various shafts described above are provided with ball bearings and hence should operate satisfactorily with little or no attention.

The members which control the clutch action may be observed by reference to Fig. 3. The clutch disengaging magnet, referred to hereinafter and on the drawings as the stop magnet, is shown in detail 1, Fig. 3. Suffice it to state that this magnet is energized whenever electrical continuity is established through the disc transmitter and the tape transmitter. Such a circuit is indicated on drawing ES-A-1181-A, from negative battery to the stop magnet, thru the stop magnet to #1 contact of the disc transmitter, thru the disc transmitter and the tape transmitter (at the time of coincidence between the pin contacts of the disc transmitter and the tape contacts of the tape transmitter) to contact #3 and thence return to battery. The stop magnet is provided with an armature, detail 2, which serves to raise pawl 3 from normal position. In normal position the pawl is clear of the ratchet wheel, 5, but in the raised position the pawl is presented before the toothed surfaces of the ratchet wheel and interferes with the movement thereof. The ratchet wheel is attached to the disc shaft.

2-14-33

Description and Operating Instructions for Converter, type M-134. Sheet #4

Hence it will be seen that clockwise motion of the ratchet wheel, with the pawl in raised position, tends to perform two functions; namely, to thrust the pawl to the left, and to stop the ratchet wheel. The pawl is mounted on a slide bar, 4, which permits of the pawl being thrust to the left for a certain distance. The slide bar is in turn yoked to the driving side of the positive clutch indicated at 6. Accordingly, motion of the slide bar to the left disengages the driving side of the clutch (keyed to the auxiliary driving shaft) from the driven side of the clutch (attached to the worm which in turn is meshed with the worm wheel driving the disc and the ratchet wheel). Upon the subsequent release of the stop magnet, the pawl is withdrawn, the slide bar is returned to normal by spring action which also engages the clutch, and the ratchet and disc are free to move forward under motor drive. This design of clutch action has certain very definite advantages because it permits of the use of a small stop magnet with light armature. The armature acts as a trigger but is not required to perform the appreciable work of disengaging the clutch. Hence the magnet action is very fast. On the other hand the inertia of the motor armature and disc is utilized to accomplish the actual work of disengaging the clutch thru the action of the ratchet wheel in forcing the slide bar to the left. Attention should be invited to the fact that at the instant the stop magnet is energized, the motor is deenergized as will be noted by reference to drawing SS-A-1181-A. The same circumstance (electrical continuity thru the disc transmitter and the tape transmitter) by means of which the stop magnet is energized, also energizes the control relay and causes that relay to open the circuit to the motor and key-locking magnet, by reason of the relay armature departing from the rear contact.

In order to obtain correct operation of the stopping devices as a whole; that is, the tape transmitter, disc transmitter, ratchet wheel, magnet pawl, and clutch, it is necessary that these elements be maintained in correct adjustment and in correct timing. The following adjustments and timing must be observed.

TIMING:

1. Tape transmitter - See that all five sets of contacts are clean and functioning properly. Be sure the rear contacts are made when the pins are depressed and that the front contacts are made when the pins are up. Also check the pin positions with perforated tape in the tape guide to be sure that the pertaining pins are actually free to move up thru the holes and are well centered with respect to the holes to allow due tolerance. This same remark applies to the tape retaining latch because the pins are required to center in the holes in the latch also.
2. Disc transmitter - All pins should be firmly seated in the drum. The adjustment of the pin contacts is very important. A gauge equivalent to the correct pin height, and hence cam motion, is supplied with each

2-14-33

Description and Operating Instructions for Converter, type M-134. Sheet #5

machine. All five contacts should be adjusted with this gauge inserted between the contact cams and drum. The tooth face of the ratchet wheel must be timed with respect to a given pin position on the drum, and also with respect to the clutch pawl. These elements are accurately timed in the assembly of the machine and therefore should not be unduly disturbed, however a certain amount of contact maintenance and adjustment may be required. In the event of installing replacement discs, the new disc must be adjusted to the correctly timed position. The replacement drums permit of such an adjustment about their square arbors. Several trials may be required to determine the correct position.

3. Clutch - The slide bar should be lubricated with vaseline on those surfaces which work in guides. This remark applies to the pawl face, ratchet teeth faces, and clutch. The clutch barrel should be lubricated with machine oil, and the gearing with oil and graphite. All screws in the assembly should be tightened periodically.

e. Disc Transmitter.

Reference Figs. 6 and 7, and drawings ES-B-1177-A, ES-A-1178-A, ES-A-1179-A, and ES-A-1181-A. The disc transmitter proper comprises a series of five sets of contacts operable by certain pins which are tapped into the periphery of a brass disc or drum, and which upon rotation of the drum by motor drive thru the transmission as described in the previous sections, perform a cam action on the central contact lever of each set. In other words the lever moves from one contact to the other contact depending upon the pin action. There are five levers, five front contacts (pins in cam position) and five rear contacts (pins out of cam position). The relationship of these elements is shown Fig. 6, detail 1. The arrangement of the pins is more or less arbitrary, but the arrangement furnished with the disc initially is as indicated on drawing ES-A-1179-A. A small socket wrench is supplied with each machine to facilitate interchanging of pins. In pin setting or contact adjustment the remarks relative to timing under Section d, Transmission, above, are pertinent.

Another element of the disc transmitter assembly is the converter. The opposite faces of the disc constitute rotor faces and are provided with studs which make contact with spring ball bearing details positioned properly about the surfaces of two stator elements between which the disc revolves. The studs on one disc face and the spring ball bearing details on the face of one stator element are shown in Fig. 7. This same figure reveals the means for removing the disc in order to clean the contacts, or to interchange

2-14-33

Description and Operating Instructions for Converter, type M-134. Sheet #6

discs. The two "U" clips, details 1 and 2, serve to key the stub shaft and the worm wheel shaft into engagement with the disc arbor. Upon removal of the "U" clips the respective shafts may be withdrawn readily from engagement with the disc arbor. The various studs on the opposite disc faces are connected together by proper wiring carried internal to the disc. The arrangement of these connections is as shown on drawing ES-A-1178-A. The function of the converter is to distribute the connections from the keys to the lamps of the lamp board. A single representative circuit is shown on drawing ES-A-1181-A where the circuit is from positive battery to a lamp, thence thru the disc to the key contacts and return to negative battery. The actual wiring for one channel is shown on drawing ES-B-1177-A. In consideration of the relatively low applied voltage and hence the necessity for maintaining contact resistance at a minimum, it is advisable that the disc studs and the stator ball bearing contacts be cleaned occasionally, dependent upon the usage of the machine. In this cleaning process the surfaces should be wiped with a cloth dampened in benzine. No other measures such as filing or scraping should be resorted to.

f. Tape Transmitter.

Reference Figs. 2, 5, 7, and drawings ES-B-1177-A and ES-A-1180-A. The tape transmitter is a commercial printing telegraph tape transmitter designed for use with the so-called Baudot five-unit code. The transmitter has been modified with regard to the wiring to contact levers and to contacts in order to suit the peculiar requirements of the converter, type M-134. The tape step forward magnet has also been rewound for operation on 8 volts. The tape transmitter is removable from the base of the unit proper, the various connections between the tape transmitter and the remainder of the unit being terminated in a multi-plug and jack arrangement. The contacts of the multiple jack (or spring clips) should be inspected occasionally for positive contact. The tape step forward mechanism may be adjusted for correct operation should the occasion warrant. The pins and pin contacts should be inspected and adjusted as described in section d, Timing, Par. 1.

g. Lamp Board.

Reference Figs. 1 and 3, and drawing ES-B-1177-A. The lamp board is an assembly of twenty-seven lamps with the necessary sockets and lamp caps. The lamp caps are designated as shown on Fig. 1. One lamp cap is blank and not in use, it having been mounted on the board simply for reasons of symmetry. The lamps proper are Eveready #1135, Mazda #40, panel indicator, 6 volts, miniature base, .15 amps., T3 bulb, Mazda B, and may be replaced as such. With reference to the drawing ES-B-1177-A, it will be noted that the lamp sockets are connected in common and the central terminal of each lamp is wired to a spring ball terminal of the disc converter stator.

2-14-33

Description and Operating Instructions for Converter, type M-134. Sheet #7

h. Battery.

An 8-volt storage battery of at least 90 ampere hour capacity should be used for proper operation of the unit. The maximum current consumption of the various elements of the unit at any instant is $5\frac{1}{2}$ amperes. This value of current is required only for those intervals during which the motor is operating. For the greater percentage of the machine operating time, the current value is approximately $1/2$ ampere. The main switch mounted on the base of the Converter, type M-134, should be operated to the "Off" position whenever the unit is idle.

13 Incls. as listed in Sec. I

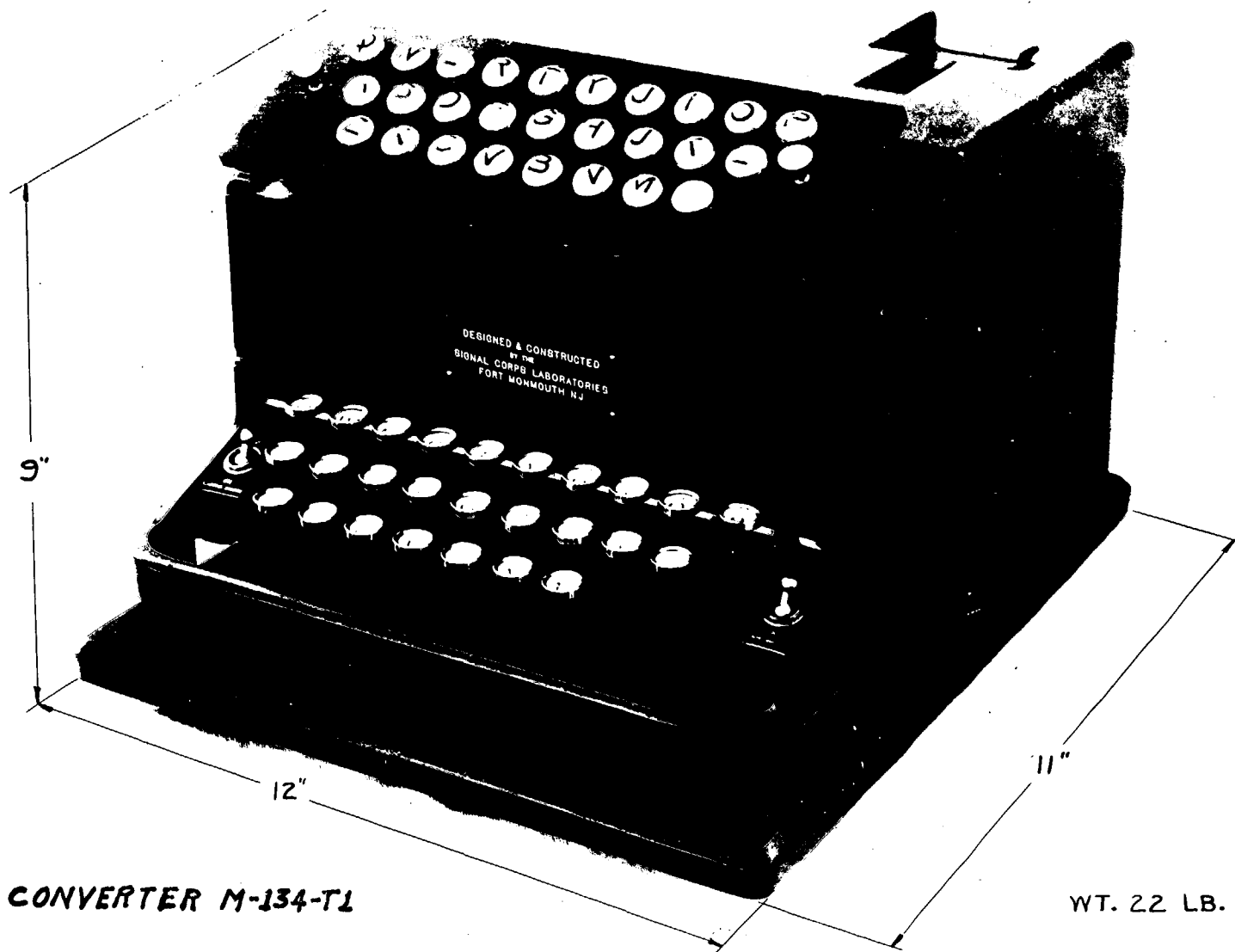
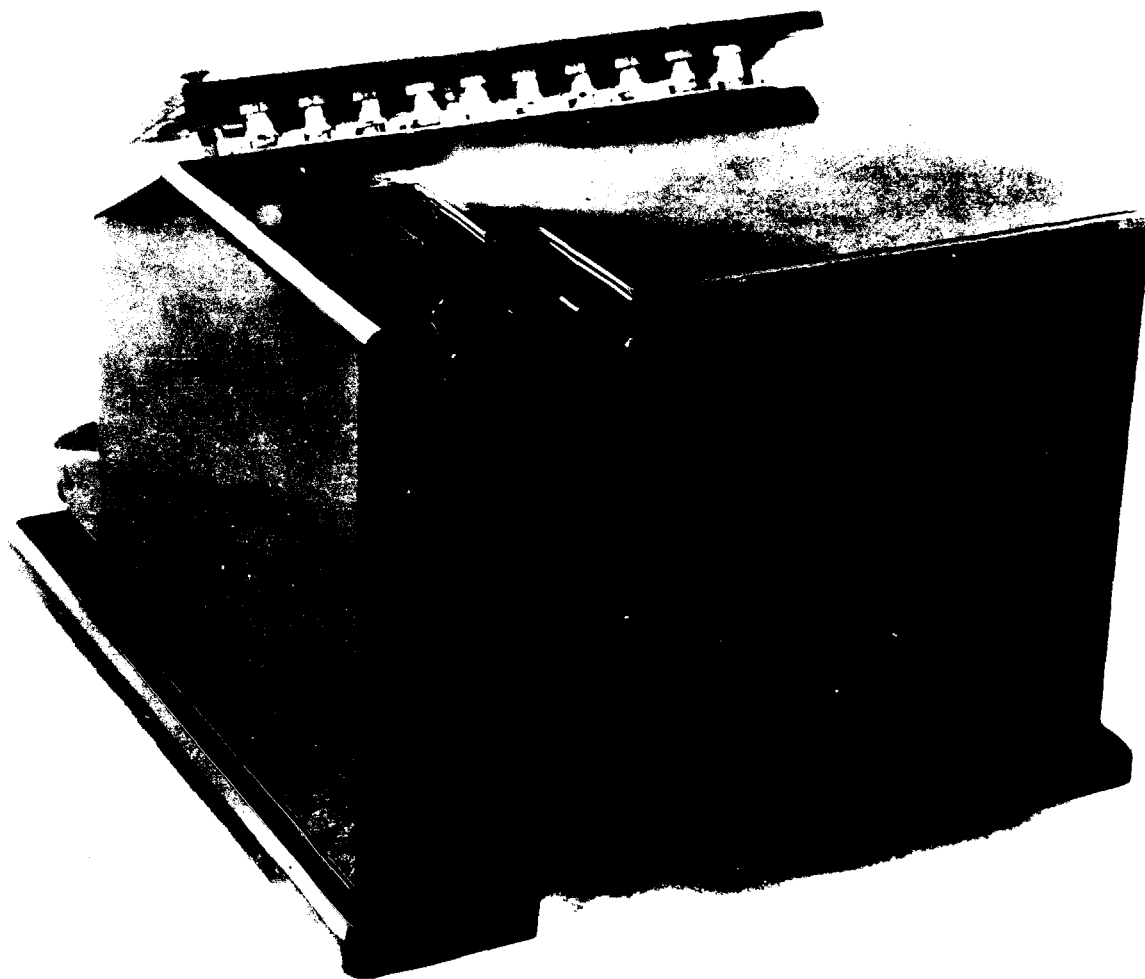
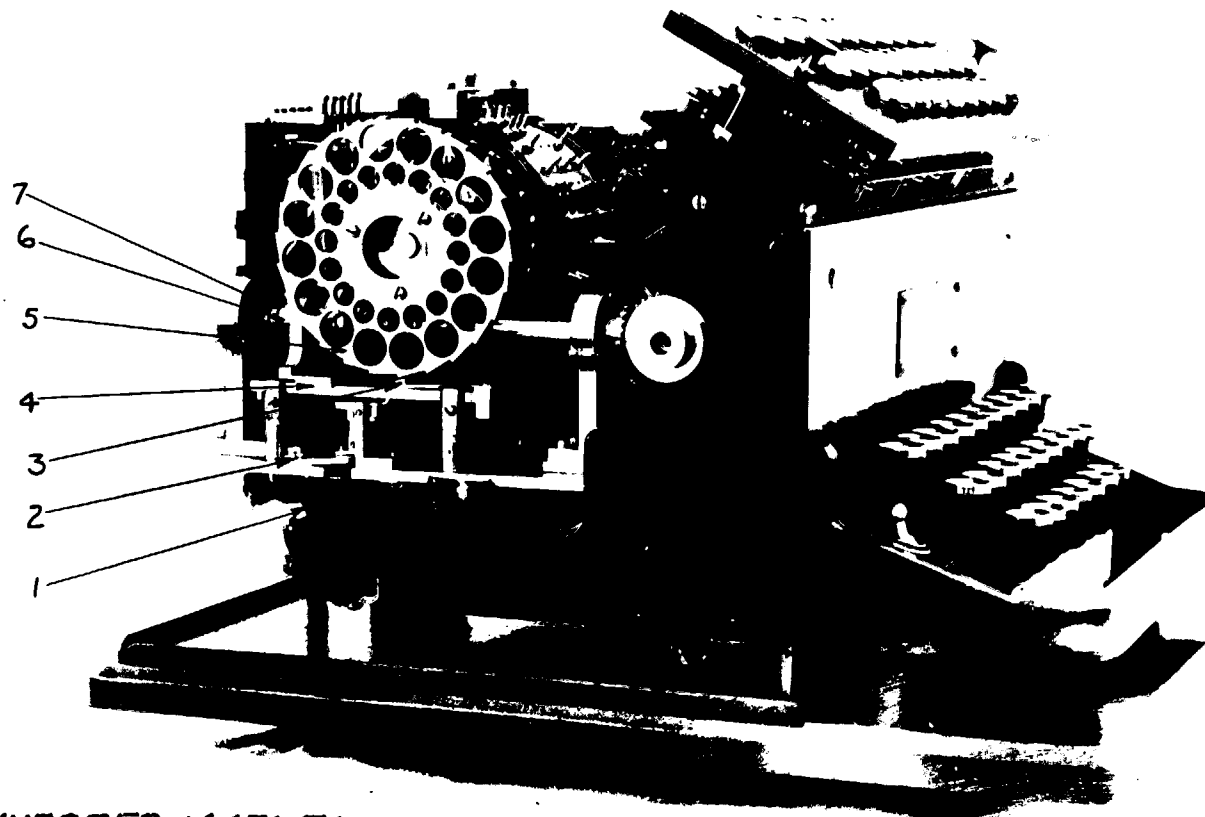

FIG. 1.



CONVERTER M-134-T1
REAR VIEW

FIG. 2



CONVERTER M-134-T1

*LEFT SIDE VIEW
COVER REMOVED*

FIG. 3

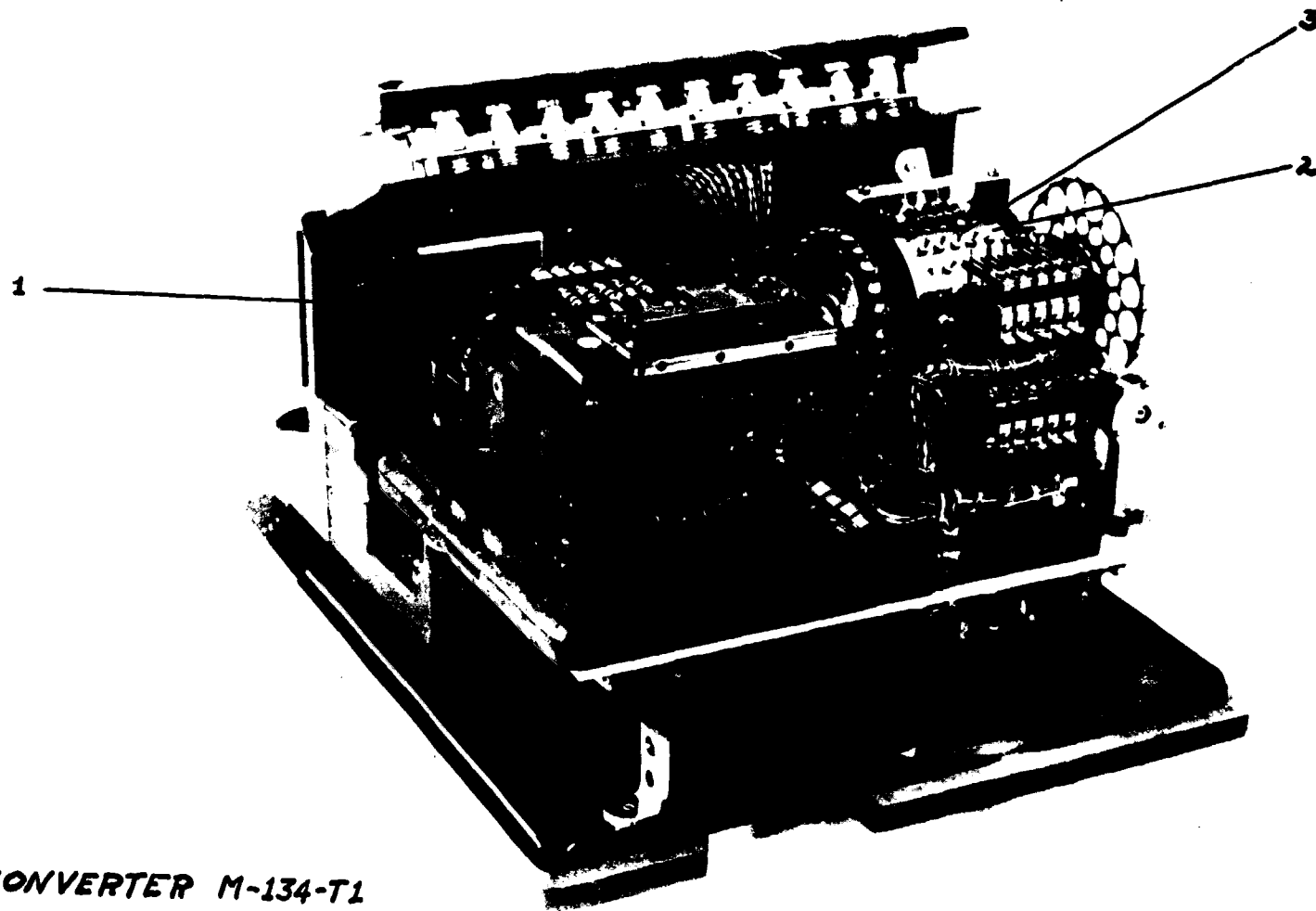

**CONVERTER M-134-T1
REAR VIEW
COVER REMOVED**

FIG. 4

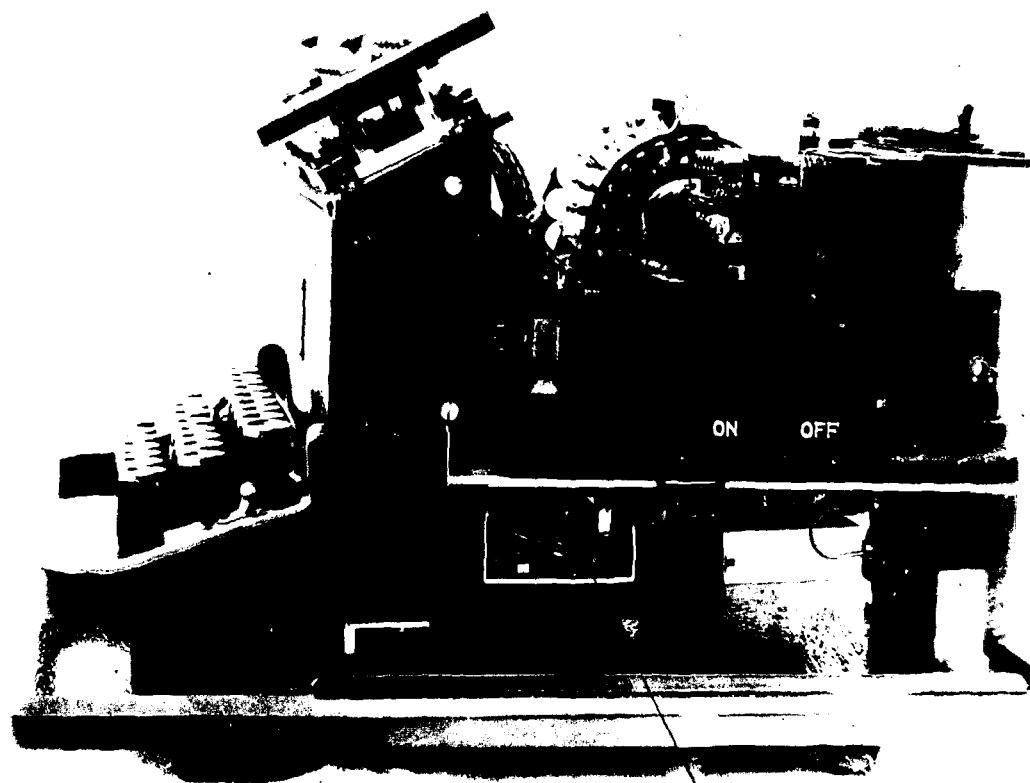

CONVERTER M-134-T1
RIGHT SIDE VIEW
COVER REMOVED

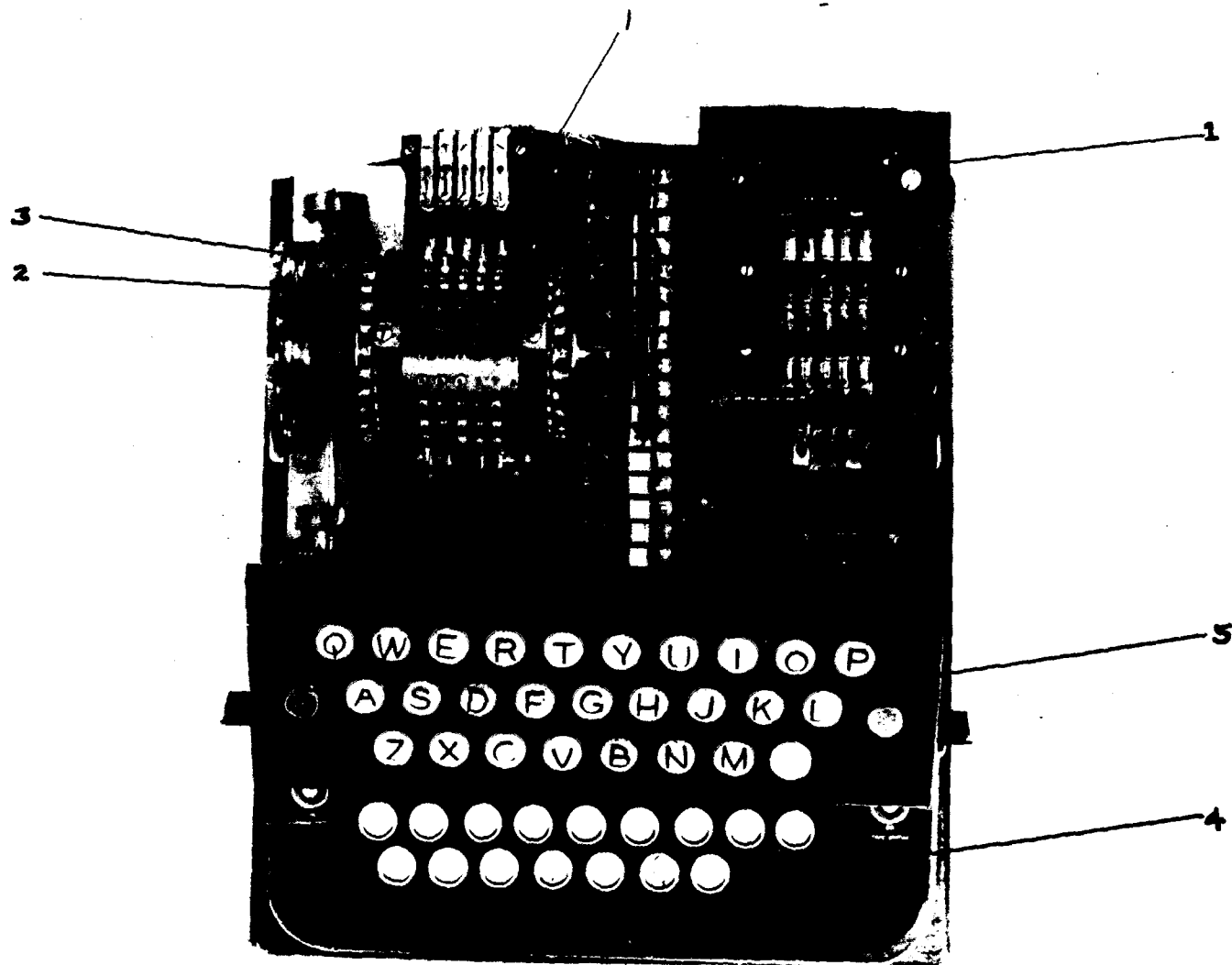

CONVERTER M-134-T1
TOP VIEW
COVER REMOVED

FIG. 6

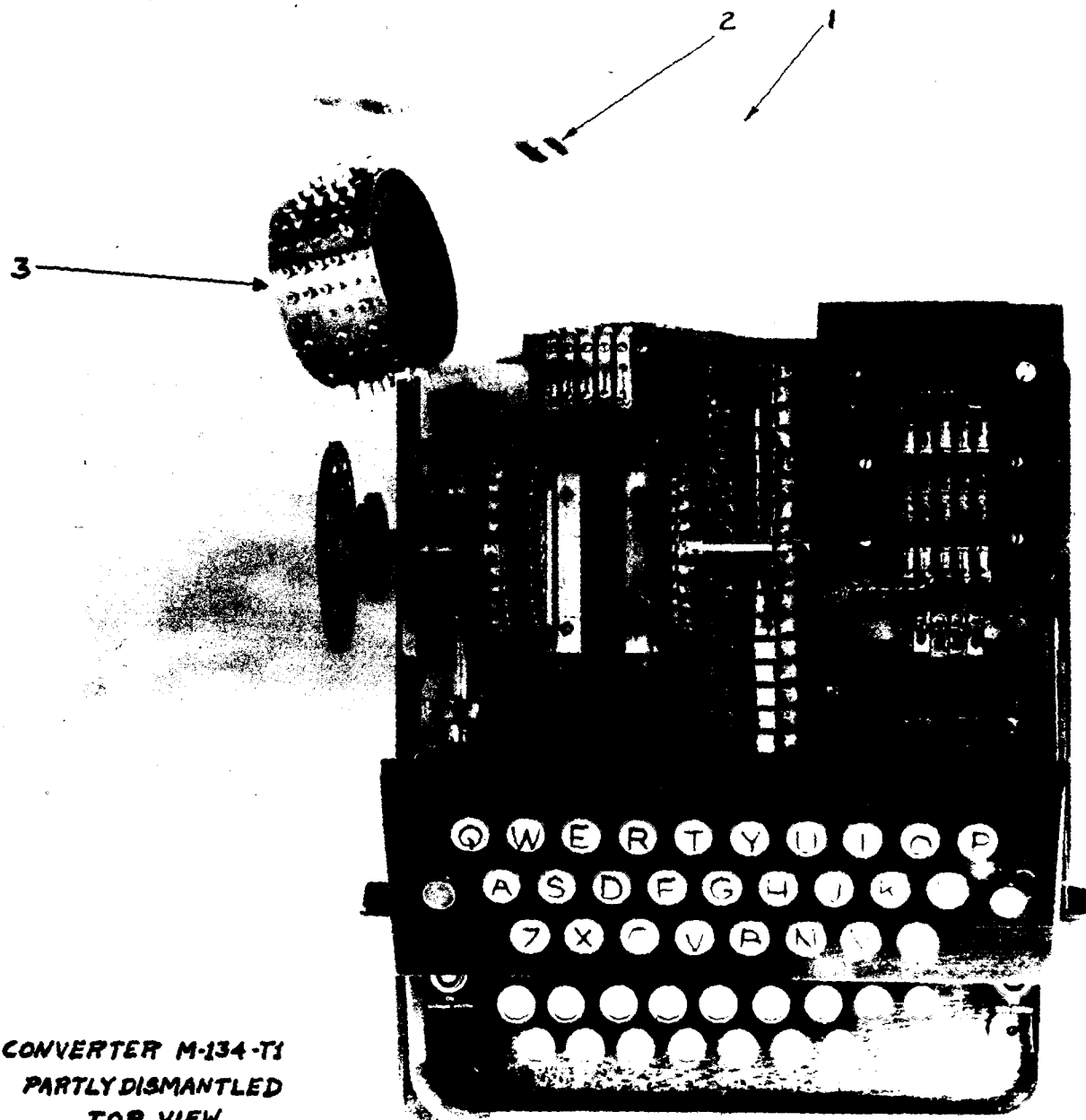

CONVERTER M-134-T1
PARTLY DISMANTLED
TOP VIEW

FIG. 7

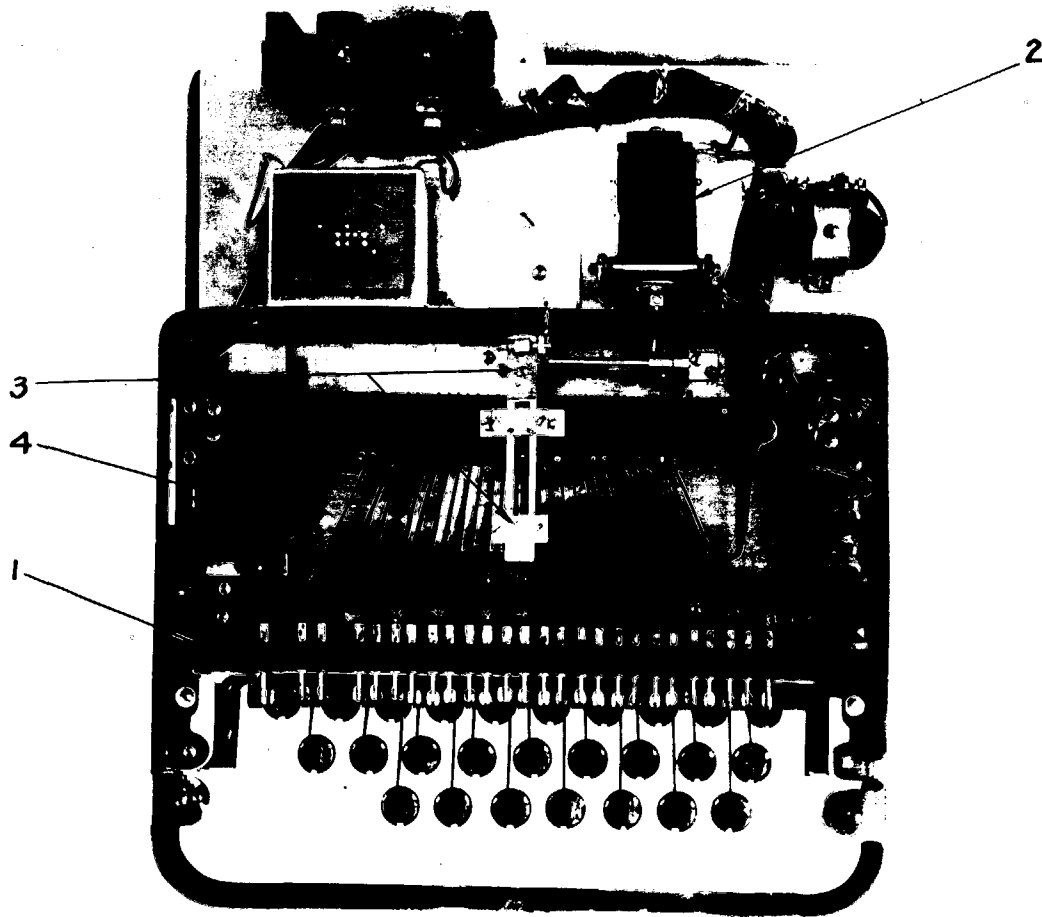

CONVERTER M-134-T1
UNDER SIDE

FIG. 8

KEY
SIDE

LAMP
SIDE

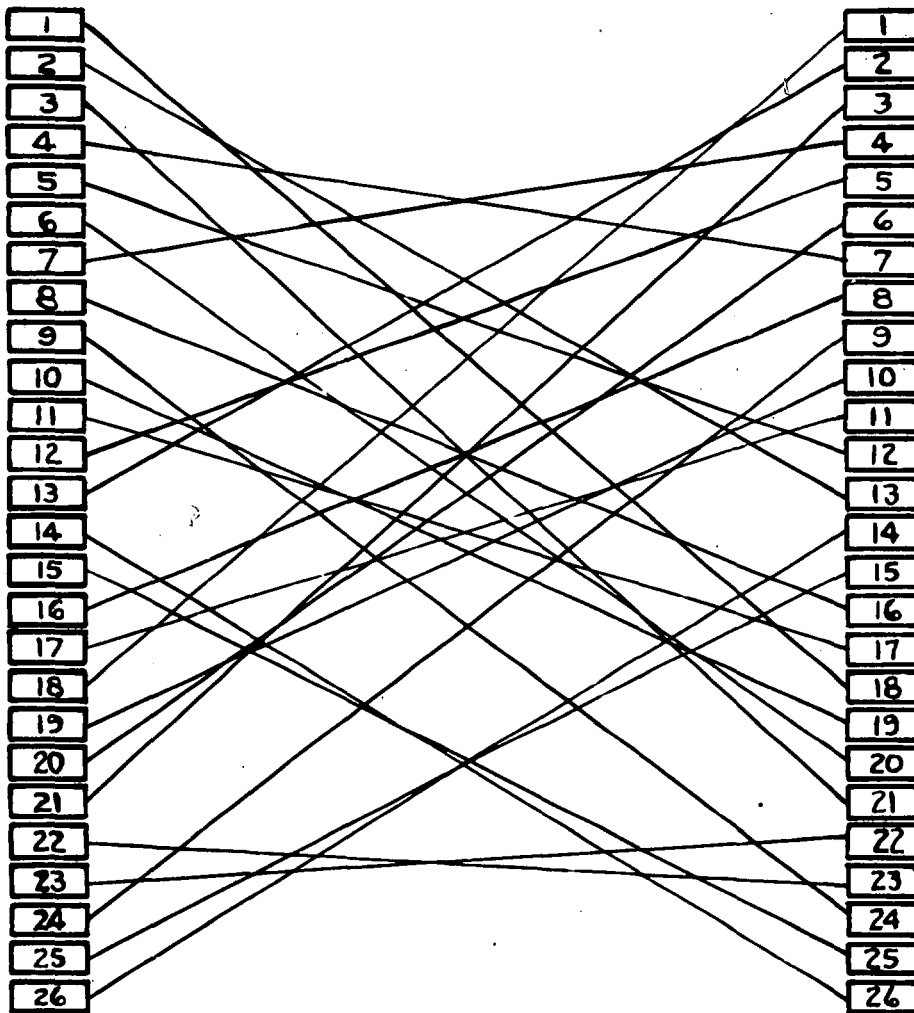

CONVERTER, TYPE M-134
DISC WIRING

AUTHENTICATION

DRAWN:HECKING

VERIFIED:

ENGINEER:

TRACED:

APPROVED:

CH. OF SEC.:

CHECKED:

DATE DEC, 12, 1932

APPROVED.

PROJ. OFFICER

SIGNAL CORPS LABORATORIES

U. S. ARMY

ES-A-1178-A

ISSUE-A 12-12-32

FORT MONMOUTH

NEW JERSEY

PIN POSITIONS IN DRUM					
PIN NO.	1	2	3	4	5
1	○			○	○
2	○	○		○	
3		○	○		
4	○		○	○	○
5			○		○
6	○				
7	○		○		
8	○	○	○		○
9	○		○	○	
10		○		○	
11		○	○	○	○
12		○			○
13					○
14	○	○	○	○	
15	○	○	○		
16	○				○
17	○		○		○
18			○	○	○
19	○	○			○
20				○	○
21	○	○			
22		○		○	○
23		○	○		○
24			○	○	
25		○	○	○	
26	○			○	

**CONVERTER, TYPE M-134
DISC PIN ARRANGEMENT**

AUTHENTICATION

DRAWN: HECKING

VERIFIED:

ENGINEER:

TRACED:

APPROVED:

CH. OF SEC

CHECKED:

DATE DEC. 12, 1932

APPROVED

PROJ OFFICER

SIGNAL CORPS LABORATORIES
U. S. ARMY

ES -A-1179-A

ISSUE-A DEC. 12, 1932

FORT MONMOUTH

NEW JERSEY

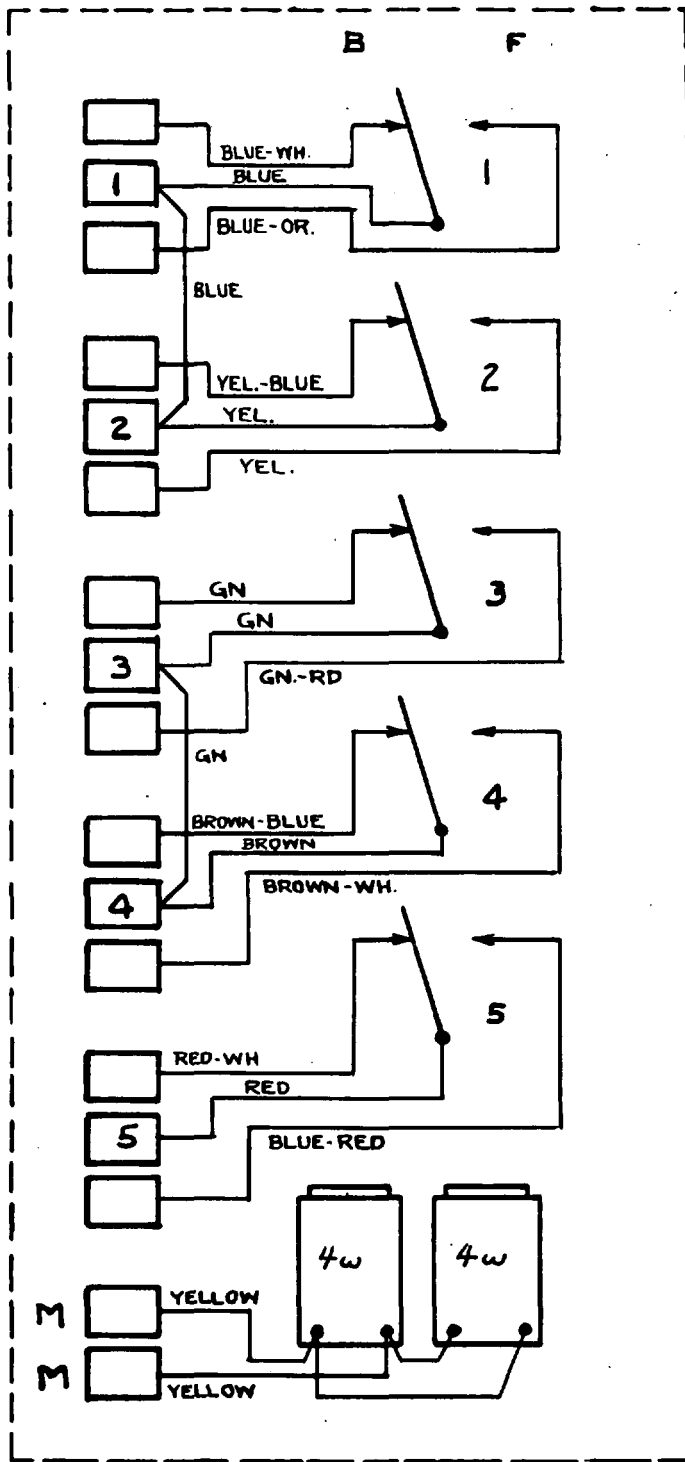

**CONVERTER, TYPE M-134
TAPE TRANSMITTER WIRING**

AUTHENTICATION

DRAWN: HECKING
TRACED:
CHECKED:

VERIFIED:
APPROVED:
DATE DEC. 12, 1932

ENGINEER: *J.A.G.*
CH. OF SEC. *J.A.G.*
APPROVED: *H.B.*
PROJ. OFFICER.

SIGNAL CORPS LABORATORIES
U. S. ARMY
FORT MONMOUTH NEW JERSEY

ES-A-1180-A

ISSUE-A DEC. 12, 1932

REF ID: A522304

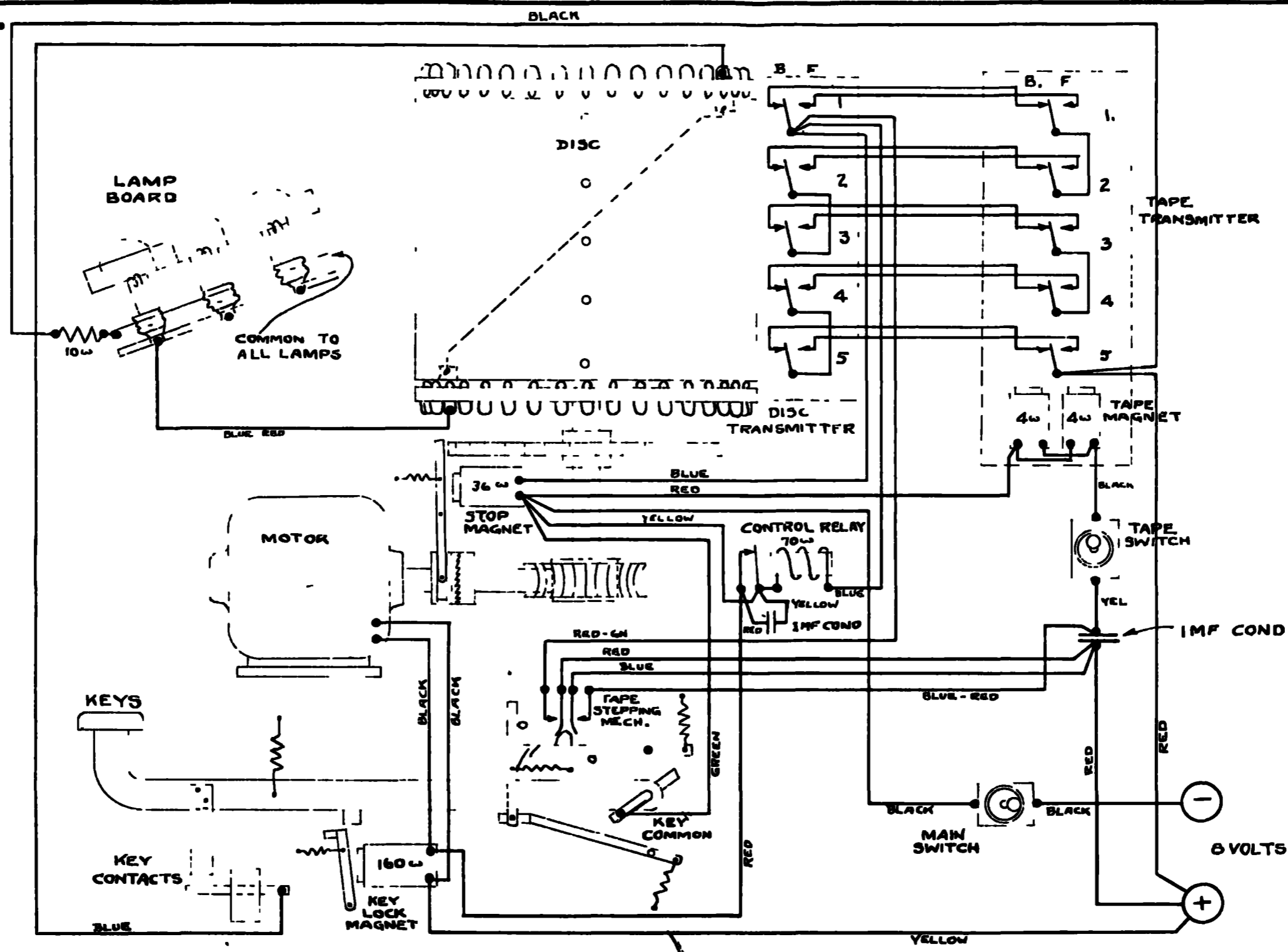

CONVERTER, TYPE M-134 WIRING DIAGRAM		
AUTHENTICATION		
DRAWN HECKING	VERIFIED	ENGINEER
TRACED	APPROVED	CH. OF SECT. <i>J.H.</i>
CHECKED	DATE 12-12-32	APPROVED PROJ. OFFICER. <i>J.H.</i>
SIGNAL CORPS LABORATORIES U. S. ARMY FORT MONMOUTH NEW JERSEY		ES-8-1177-A

ISSUE-A 12-12-32